

# 25-FOOT SOUND STAGE LAYOUT

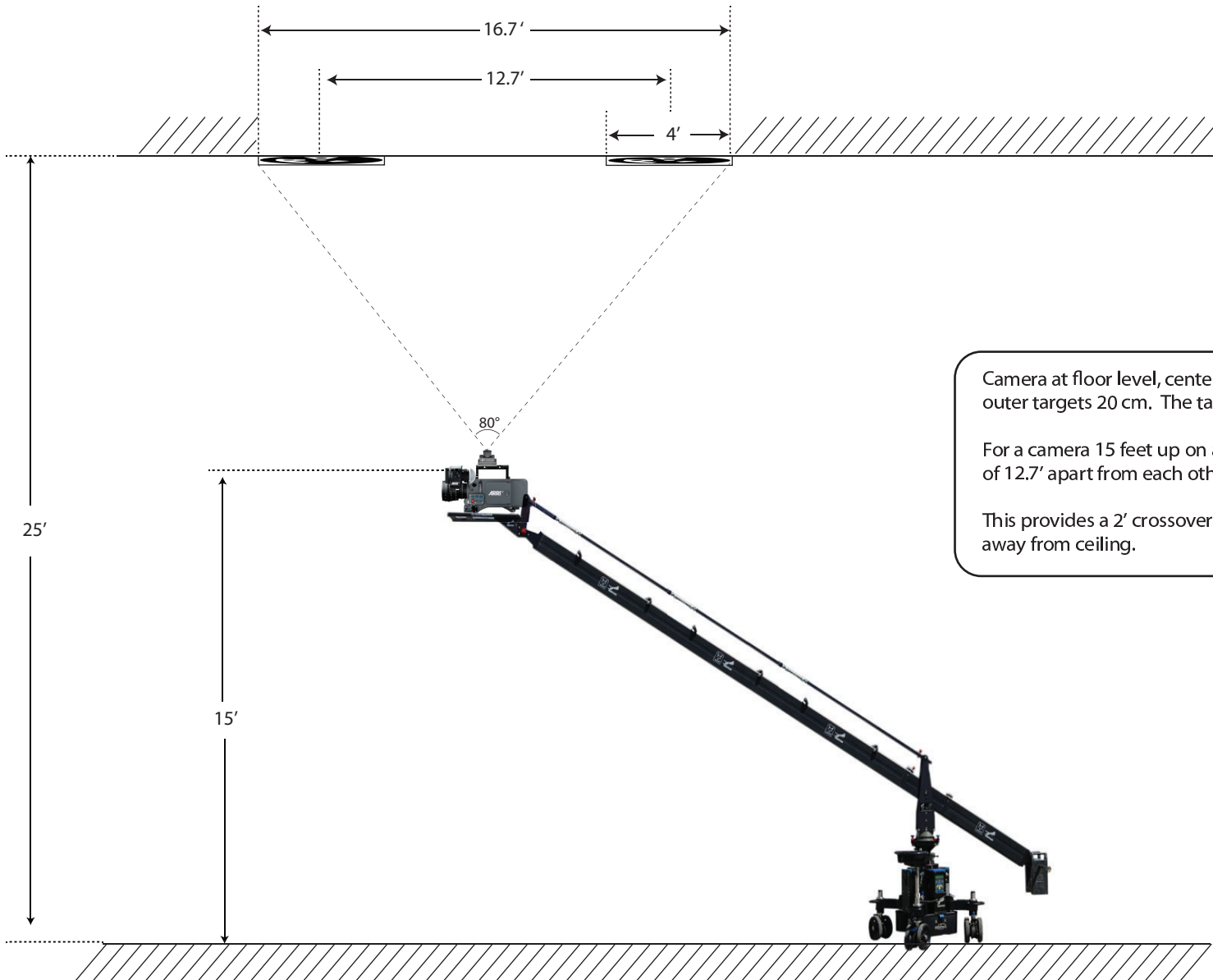

Camera at floor level, center targets should be 50 cm and outer targets 20 cm. The targets should be 4 feet wide.

For a camera 15 feet up on a jib, targets should be a maximum of 12.7' apart from each other.

This provides a 2' crossover zone of the 20cm targets from 13' away from ceiling.

Scale (1:60)

← 5 feet →